

## 1. General

### 1.1 Structure

The **SCGC-1GL** clip-on generator set is a self-contained, automatic, diesel engine powered generator set that supplies electrical power for container refrigeration systems.

The **SCGC-1GL** clip-on generator set is designed for mounting to the upper front structure of an ISO reefer container. The design incorporates quick connections to the upper container corner castings. Additional attaching points on the container vertical structural members provide a secure mounting arrangement.

The forklift pockets are provided at the bottom of the generator set. The forklift pocket ends are close to prevent refrigeration unit damage.

The unit frame contains the water cooled engine and engine accessories, generator, battery, control box and gauges.

### 1.2 Structural Frame and Integral Fuel Tank

The fuel tank is tested and cleaned by diesel fuel at 80-120kpa pressure, the frame and outer surface of the fuel tank are primer coated with an epoxy ester chrome-free paint immediately after shot-blasting, and then finish coated with a high solids polyester baked-on enamel paint. Surface color is black.

### 1.3 Panels and Doors

Metal-door, control box, receptacle box are primer coated with an epoxy-ester chrome-free paint immediately after shot-blasting, and then finish coated with high polyester baked-on enamel paint. Surface color is white.

### 1.4 Hardware

All hardware and hinges are stainless steel or electro-less nickel plated for maximum protection from salt water corrosion.

### 1.5 Unit dimension (mm), weight (Kg), Fuel tank capacity (L/gal)

Model	Width	Height	Depth	Weight	Fuel tank capacity
SCGC-1GL	2310	1100	732	880	410/108

### 1.6 Operation temperature range

-25°C to +55°C

### 1.7 Alternator set rating

15.0kW, 18.75kVA at 0.8 power factor

460 V, 3-phase

60Hz at 1800rpm.

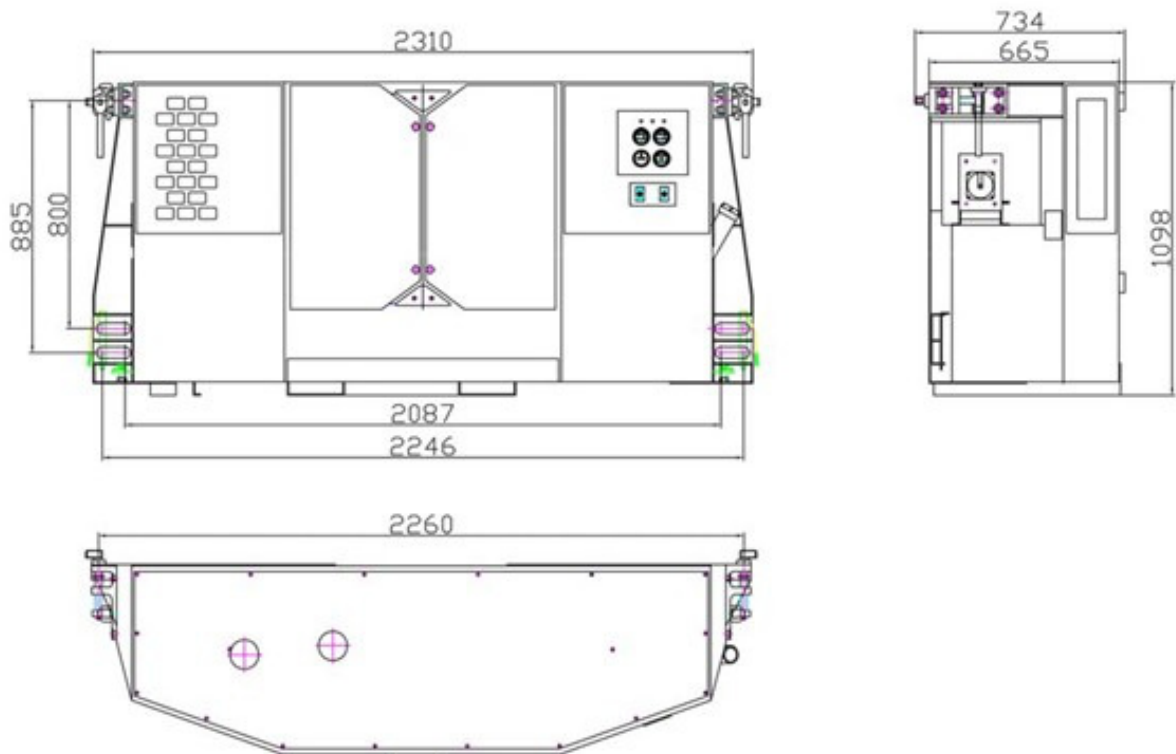

**SCGC-1GL clip-on generator set outline drawing**



**SCGC-1GL clip-on generator set appearance**



**SCGC-1GL clip-on generator set inner structure**

## 2. Engine

2.1.1 Manufacturer: **SHAN DONG HUAYUAN LAIDONG ENGINE CO., LTD.**

2.1.2 Model: **4L22BD-RF**

2.1.3 Emission regulation :



**4L22BD-RF engine appearance**

2.1.4 Technical specification of 4L22BD-RF engine:

Type	Vertical in-line, water-cooled , 4-cycle diesel engine
Number of cylinders	4
Bore	85mm
Stroke	95mm
Total displacement	2.156L
Max. rated output (kW)	21/1800rpm
Continuous rated output (kW)	19/1800rpm
Specific fuel consumption	258 g/ kW.h at rated output
Firing order	1-3-4-2 -1(order from FAN)
Direction of rotation	Counterclockwise viewed from flywheel end
Fuel injection pump	KANGDA made
Fuel filter	paper element
Cooling system	liquid-cooled with radiator
Coolant capacity	8-10L (including reserve tank)
Coolant high temperature switch	97°C ± 2°C
Lubricating system	Forced lubrication with trochoid pump
Oil filter	paper element
Oil tank capacity	6L
Oil pressure	245kPa~441kPa at 1800rpm
Low oil pressure switch	100kPa±20kPa
Air cleaner type	Heavy-duty oil bath filter air cleaner
Starting system	Starting motor DC12V, 3.2kW
Starting aid	Air heater 12VDC, 380W, 35A
Charging generator	DC14V, 350W

### 3. Generator

Manufacturer: **MARATHON**

Model: **RF-15-CIMC**

#### 3.1 General

RF-15-CIMC three phase A.C. synchronous brushless generator is based on the technology of Marathon Electric CO. It is combined with diesel engine to make movable electrical power for container refrigeration system. RF-15-CIMC generator is of unique design, advanced construction, excellent performance, reliable operation, easy, small volume and light weight.

1) RF-15-CIMC generator is manufactured in accordance with NEMA ODP type (IP22). It consists of main generator, AC brushless exciter, rotating diode, auxiliary winding, terminal box, etc.

2) Class H insulation per NEMA MG-1-1.65, maximum temp rise: 125°C.

3) The frame is made of steel plate. The design of stator lamination is unique. 10 lead wires is supplied.

4) Main rotor use the single piece 4-pole salient pole lamination, coupled with die cast or welding damping winding, field winding to form a unirotor construction, the field winding is layer wound with thermo setting epoxy for high mechanical and electrical integrity.

1) Drive disc radial fan cooling method.

2) Laminations and wiring are protected against salt water with epoxy primers, epoxy impregnation (three times) and epoxy coating.

7) Generator Rating:

15 kW、 18.75 kVA 、 0.8 power factor or

RPM: 1800

Voltage: 460

Phases: 3

Frequency: 60 Hz

8) Dust-proof bearing, sealed and lubricated with synthetic hydrocarbon.



**RF-15-CIMC generator appearance**

#### 3.2 Generator function-voltage regulation

1) starting excitation

The initial excitation of the generator is supplied by permanent magnet steel which is

mounted on exciter field.

2) Running excitation and control

The rectifier (6) is fed by an auxiliary winding (5) located in the stator.

When starting the residual magnetism creates a current in the exciter armature (1). This current is rectified by the rotating diodes (2) and feeds the main field (3). The induced voltage in the auxiliary winding (5) is then used to increase the excitation power via rectifier (6) to exciter field (7) so as to ensure a rapid and smooth build up of output voltage in the main stator winding (4).

3) Boosted output current during temporary over load periods such as motor or compressor start up.

The auxiliary winding (5) is triple-frequency harmonic winding. For temporary over loads (such as refrigeration unit start up), the excitation control system utilizes the auxiliary winding to handle the overload. When an overload occurs, the increase current flow from the alternator stator, which causes an immediate increase in the auxiliary winding current. This increased output boosts the output of the alternator to handle the temporary overload by exciter field.

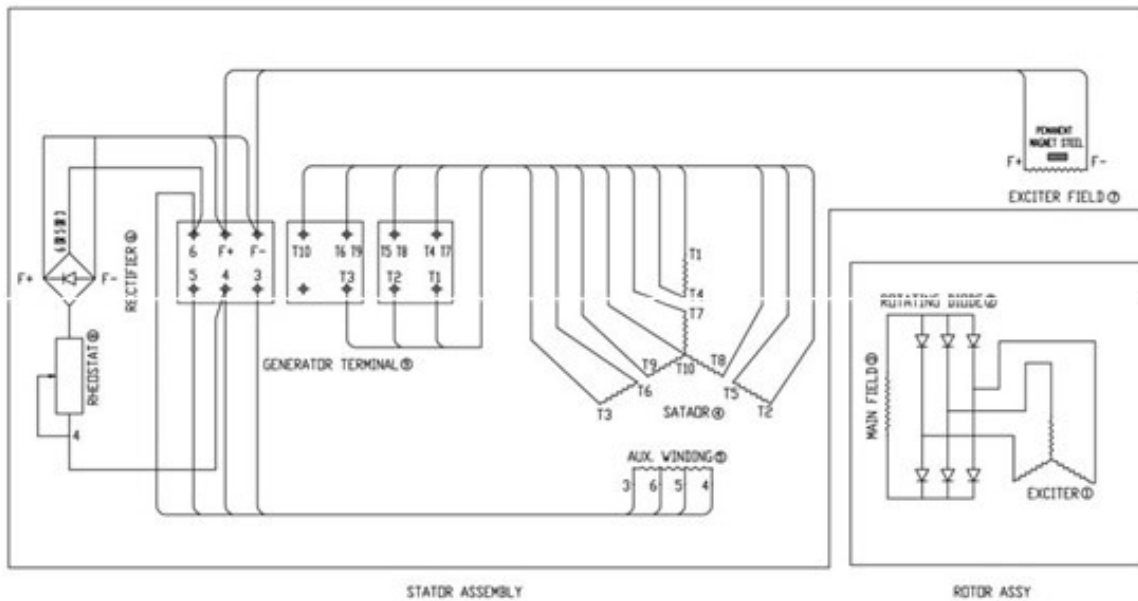

## 4. Control system

### 4.1 Components of control panel:

- Engine hour meter、 water temperature gauge、 oil pressure gauge、 charging ammeter
- Preheat/start switch、 on-off switch
- Fault display lamps
- Safety stop control units

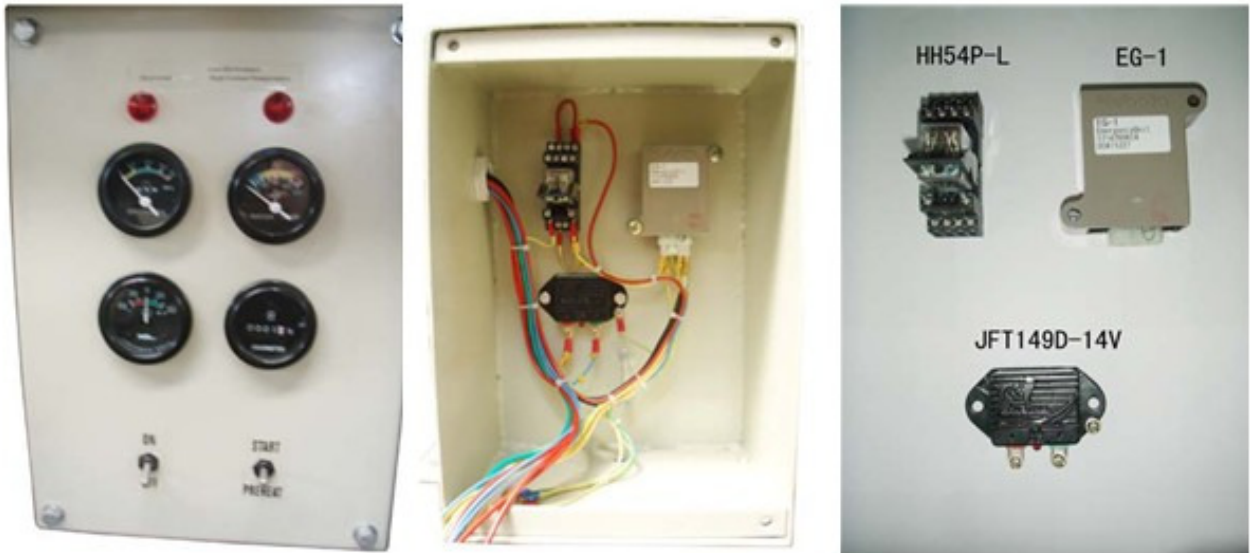

SCGC series generator set control box

### 4.2 Unit control

- 1. ON-OFF SWITCH:** The unit ON-OFF switch energizes the electrical system of the unit when in the ON position. In the OFF position, it de-energizes the fuel solenoid to stop the engine.
- 2. PREHEAT/START SWITCH:** When pressed to PREHEAT, the PREHEAT/START switch energizes the air heater to aid in starting the diesel engine. When pressed to START, the PREHEAT/START switch energizes both the air heater and the starting motor. Hold the switch on START until the engine starts to fire and picks up speed. DO NOT release the switch from the START position prematurely when engine is extremely cold.
- 3. ENGINE SHUTDOWN INDICATOR:** Indicates an over load、 low oil pressure and high coolant temperature



On/off switch



Preheat/start switch

#### 4.3 Unit instrument

1. **AMMETER:** The ammeter indicates battery charging and discharging amperage during engine operation. The charging amperage varies according to the needs of the battery. The ammeter also indicates the amount of current draw by the air heater during preheat.
2. **HOURMETER:** The engine hour-meter records the total hours that the engine is in operation so proper maintenance can be scheduled.
3. **OIL PRESSURE GAUGE:** The oil pressure gauge indicates engine oil pressure. Engine oil pressure should rise immediately on starting.
4. **ENGINE COOLANT TEMPERATURE GAUGE:** The engine coolant temperature gauge indicates the temperature of the engine coolant in the block.
5. **FUEL GAUGE:** A gauge mounted in the integral fuel tank indicates the level of diesel fuel in tank.



Charging ammeter



Hour meter



Oil pressure gauge



temperature gauge

#### 4.4 Unit protection device

**LOW OIL PRESSURE SWITCH:** Engine oil pressure shall rise immediately when starting. A low oil pressure switch will ground, stop the engine and the low oil pressure shutdown indicator will light if oil pressure drops below  $100 \pm 20$  kpa.

**ENGINE COOLANT HIGH TEMPERATURE SWITCH:** If the engine coolant temperature rises  $97 \pm 2$  °C, the coolant high temperature switch will ground, stop the engine and the high temperature shutdown indicator will light.

**CIRCUIT BREAKER:** A circuit breaker (CB1) is located behind the generator terminal box face or the receptacle box face. It will trip, the aux. contact will ground and stop the engine if the 460 VAC power circuit overloads above 25 amps under operation and the overload shutdown indicator will light.

*The circuit breaker must be manually reset.*



Coolant temperature sender and switch



Oil pressure sender and switch



Circuit breaker



Solenoid



#### 4.5 Protection Feature

- ⌘ Safety stop control for engine low oil pressure
- ⌘ Safety stop control for engine high coolant temperature
- ⌘ Safety stop control for generator short circuit or over load

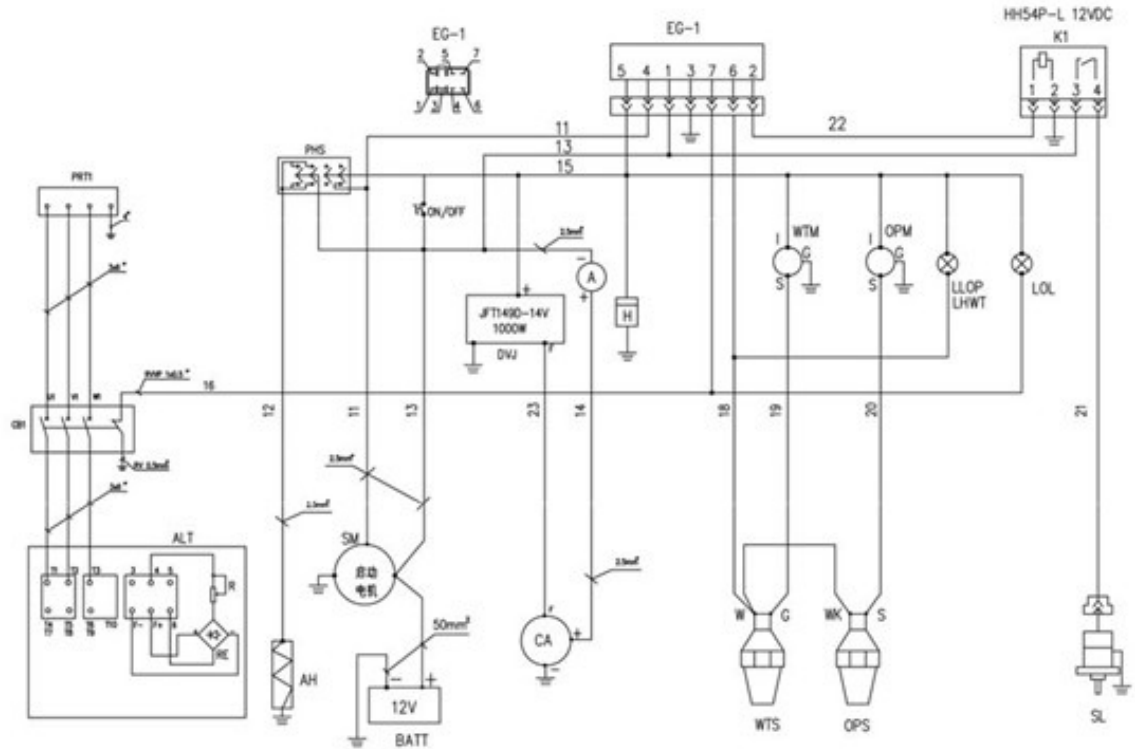

#### LEDGEND:

**PRT1:** Power cable receptacle (32A,460V)

**CB1:** Circuit breaker((32A,460V)

**ALT:** Generator terminal

**R:** Resistor

**RE:** Bridge rectifier

**EG-1:** Safety stop control unit

**H:** Hour meter

**LOL:** Over load lamp

**LLOP:** Low oil pressure lamp

**LHWT:** High coolant temperature lamp

**PHS:** Preheat/start switch

**ON/OFF:** On/off switch

**A:** Charging ammeter

**WTM:** Coolant temperature gauge

**OPM:** Oil pressure gauge

**AH:** Air heater

**BATT:** Battery

**SM:** Starter

**CA:** Charging alternator

**DVJ:** Charging alternator adjuster

**WTS:** Coolant temperature sender and switch

**OPS:** Oil pressure sender and switch

**EFP:** Electrical fuel feed pump

**SL:** Solenoid

**K1:** Glow relay



## 5. Auxiliary systems

### 5.1 12VDC maintenance-free battery

Engine battery shall be maintenance-free with 625 cold cranking amps at -18°C.

Cold Cranking Amps: 625Amps for 30 seconds at -18°C

Reserve capacity: 25Amps output for 160 min. at 27°C

Battery charging current is supplied by the DC charging generator

### 5.2 ISO standard power cable receptacle

Electric power receptacle shall be designed in accordance with the C.E.E. standards and I.E.C. recommended specifications, including I.S.O, and to operate when the nominal voltage measured among phases is as below :

- a) 60HZ; 400V min., 500V max.
- b) 32 Amperes, 3 wire-4 pole, C.E.E. Earth contact position -3 h.



**Battery**



**Power cable receptacle**

**6. Acceptance certificate**

**SCGC**  
**GENERATOR SET ACCEPTANCE CERTIFICATE**

UNIT MODEL:

UNIT SERIAL NUMBER:

CUSTOMER NAME:

CUSTOMER UNIT No:

CHECK-OUT SITE:

CHECK-OUT DATE:

TECHNICIAN:

CUSTOMER SIGNATURE:

**VISUAL INSPECTION**

- 1 Inspect all components, ensure none are missing or physically damaged ( )

**UNIT FUNCTION INSPECTION**

- 1 Check for leaks ( )
- 2 Inspect the wiring for loose connections ( )
- 3 Check belt tension ( )
- 4 Check the anti-freeze, radiator full and 50/50 mixture ( )
- 5 Check engine oil level, add if necessary (API type CD or CF-4) ( )
- 6 Connect the battery ( )
- 7 Check engine fuel level, add if necessary ( )
- 8 Start the unit (refer to maintenance manual of section 3) ( )
- 9 Inspect for leaks: fuel ( ) coolant ( ) oil ( ) gas ( )
- 10 Check abnormal noise and vibration ( )
- 11 Check oil pressure gauge (within  $3.5 \pm 1.0 \text{kg/cm}^2$  in cold state) ( )
- 12 Check hour meter ( )
- 13 Safety stop control system (engine stops and lamps display) ( )
- a) coolant high temperature ( )
- b) low oil pressure ( )
- c) main breaker tripping ( )
- 14 Check voltage and frequency ( )
- Under load (8 kW~15kW, 0.75~0.80 power factor)
- Volts(v) L1-L2( ) L2-L3( ) L3-L1( ) Volt. within 420~500V
- Freq.(Hz) ( ) Freq. within 58.2~61.8Hz
- 15 Comments:

## 7. The clip-on generator set installation

1. Install clamp handle and slotted spring pin. refer to the picture 01 and 02 , before the clip-on generator set is used for the first time.

Caution: the mounting clip-on the head of the clamp shaft must be horizontal and outward , the clamp handle must be vertical and downward.



Picture 01

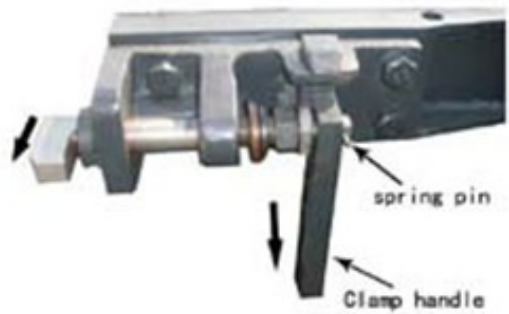

Picture 02

2. Lift the lock block and turn the clamp handle to rotate the clamp shaft 90 degree (*the mounting clip is vertical* ). refer to the picture 03

Release the lock block to hold the clamp handle. refer to the picture 04



Picture 03



Picture 04

3. Lift the generator set into mounting position on front wall of the container. Foot of generator set mounting clamp should fit into mounting hole on each side of the container. refer to the picture 05、 06

Caution: take adequate precautions when lifting and mounting the generator set to prevent personal injury or unit damage.



**Picture 05**



**Picture 06**

4. When the Foot of generator set mounting clamp fully inserted into the container mounting hole, lift the lock block and return the clamp handle to rotate the clamp shaft 90 degree(*the mounting clip is horizontal*). Release the lock block to hold the clamp handle. refer to the picture 07、 08

Caution: watch the mounting clip on the head of the clamp shaft when rotating the clamp handle. *The mounting clip must be horizontal*. Rotating the clamp handle is easy by loosening the locknut on the clamp shaft.



**Picture 07**



**Picture 08**

5. Check to the mounting clip should pull the generator set frame tight against the container front wall. *The mounting clip must be tightened by turning the locknut on the clamp shaft*. refer to the picture 09、 10、 11



Picture 09



Picture10



Picture 11

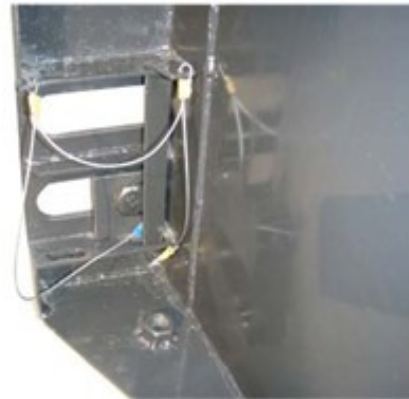

Picture 12

6. Install the lower mounting bolts

- a) Remove the retaining pin from the lower mounting bracket.
- b) Remove the mounting blot and backup plate from the keeper nut. Put the mounting bolt through the backup plate and install the bolt in the mounting screw hole of container.
- c) Tighten the lower mounting bolts
- d) Install the retaining pin and hair pin key to prevent accidental loss of the mounting blot and backup plate during unit operation refer to the picture 12

